



# WRT

## Rider Electric Power Pallet Truck

HEAVY DUTY END-CONTROL RIDER PALLET TRUCK IDEAL FOR MANUFACTURING AND LARGE WAREHOUSE APPLICATIONS



### CAPACITY

6000 lbs.

### BATTERY

Compartment: 31.12" x 13.12" x 31.62  
Anderson 175 Gray—A-11 Min/Max battery weight 975/1500lbs.

### SPEED

Variable 0 mph up to 9.0 mph empty  
Variable 0 mph up to 6.5 mph loaded

### WEIGHT

1528 lbs. Chassis Only

### TIRES AND WHEELS

#### DRIVE

10" x 4" polyurethane

#### STABILITY CASTER WHEELS

2 - 3.9" x 2.5" polyurethane

#### LOAD

2 - 3.25" x 6.5" polyurethane

### OPERATOR AREA - CONTROLS

The WRT 60 stand-up end control power pallet truck has a large operator platform which increases operator comfort and productivity. Careful location of ergonomic operator handle feature easy to use controls for travel, lift, lower and horn functions. All operator controls are accessible without having to lift the hand from the handle. Large thumb control lever for forward and reverse travel allows travel as a rider truck or walkie.

Microcellular rubber floor mat and angled power head cover are designed to allow easy operation with either hand and improved operator comfort.

Smooth urethane high speed grab bar for operator security with one touch high speed button.

### ELECTRICAL

Heavy-duty, 24-Volt system for demanding warehouse applications. The programmable ZAPI traction control and matching drive motor provide high performance throughout the entire speed range.

Travel speed remains constant relative to throttle position regardless of load. Separately fused power control circuits, quick disconnect EPD power cut off, hour meter / battery discharge indicator combination gauge complete the system. Power configurations and diagnostic features are standard.

### HYDRAULICS

Heavy duty pump motor with center mounted lift cylinder. Heavy-duty, pump unit, motor, hydraulic reservoir, solenoid, and gear pump. Integral pressure compensated flow control valve regulates lowering speeds.

### DRIVE UNIT

Vertically mounted drive motor is directly mounted to gear housing. Oil bathed hypoid bevel gear drive train with tapered roller bearings transfers power to axle. State of the art optimized gear technology supplies advantages such as minimal envelope circle, zero maintenance, low noise level, high efficiency and high performance. Regenerative electromagnetic brake is mounted on motor armature shaft multiplying the braking power through the transmission. Brake is applied when control arm is in the vertical or horizontal handle position. System features anti-roll back and neutral braking.

### CASTER SYSTEM

Heavy duty spring loaded, articulating systems designed to stabilize truck performance and increase operator comfort.

### FORK ASSEMBLY

Pallet entry slide allows easy pallet entry by lifting the fork up and over bottom board. Eight easily accessed grease zerks for ease of maintenance. Tapered extended fork tip design is available on double pallet handling models.

### ACCESSIBILITY

Heavy duty composite two piece cover exposes major components for inspection and maintenance.

### STANDARD EQUIPMENT

- 24-Volt regenerative braking
- Large AC traction motor
- Microcellular rubber floor mat
- Two piece powerhead cover
- Tapered fork tips w/entry skid plate
- Programmable performance travel / plugging / braking
- Ergonomic high speed bar

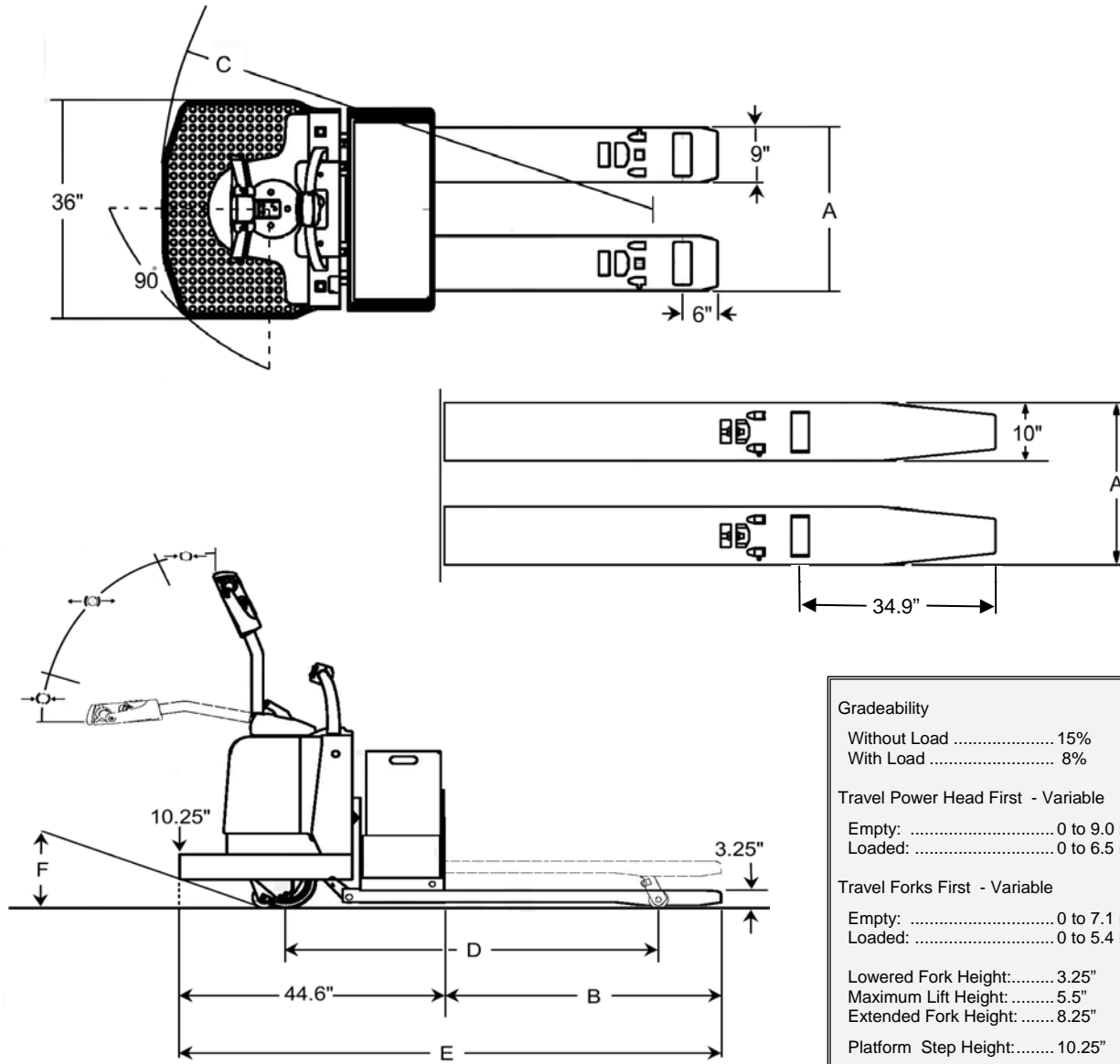

|   |              |
|---|--------------|
| <b>Gradeability</b>                       |              |
| Without Load .....                        | 15%          |
| With Load .....                           | 8%           |
| <b>Travel Power Head First - Variable</b> |              |
| Empty: .....                              | 0 to 9.0 mph |
| Loaded: .....                             | 0 to 6.5 mph |
| <b>Travel Forks First - Variable</b>      |              |
| Empty: .....                              | 0 to 7.1 mph |
| Loaded: .....                             | 0 to 5.4 mph |
| Lowered Fork Height:.....                 | 3.25"        |
| Maximum Lift Height: .....                | 5.5"         |
| Extended Fork Height: .....               | 8.25"        |
| Platform Step Height:.....                | 10.25"       |

| Model #                          | Forks   | Fork Width | Actual Fork Length | Turning Radius | Wheelbase | Overall Length | Grade Clearance | Weight (lbs.) <sup>3</sup> |
|----------------------------------|---------|------------|--------------------|----------------|-----------|----------------|-----------------|----------------------------|
|                                  |         | A          | B                  | C              | D         | E              | F               |                            |
| <b>Fork Dimensions: 27" Wide</b> |         |            |                    |                |           |                |                 |                            |
| WRT60                            | 27 x 36 | 27         | 35.5               | 68.9           | 55.8      | 80.1           | 38%             | 1175                       |
| WRT60                            | 27 x 48 | 27         | 46.9               | 81.2           | 67.8      | 91.5           | 30%             | 1254                       |
| WRT60                            | 27 x 60 | 27         | 59.5               | 59.8           | 67.8      | 104.1          | 25%             | 1354                       |
| WRT60                            | 28 x 96 | 28         | 95.6               | 101.9          | 88.6      | 140.2          | 17%             | 1595                       |
| <b>Fork Dimensions: 22" Wide</b> |         |            |                    |                |           |                |                 |                            |
| WRT60                            | 22 x 36 | 22         | 35.5               | 68.9           | 55.8      | 80.1           | 38%             | 1175                       |
| WRT60                            | 22 x 48 | 22         | 46.9               | 81.2           | 67.8      | 91.5           | 30%             | 1254                       |

<sup>2</sup> Extended-tip Forks

<sup>3</sup> Estimated shipping weight without battery